

■ BOLTS and SHAFTS for rotating and oscillating movements

Direct delivery by manufacturer:

- Recrystallised, fine-grained austenitic manganese steel forged structure (X120Mn12; Hadfield Steel; 1.3401)
- Tempered, fine-grained forged structure of various quenched and tempered steels such as 1.6582 (34CrNiMo6), 1.7225 (42CrMo4) and 1.8159 (50CrV4)
Other grades available on request.
- Flexible and short delivery times
- Economic advantage

Bolt shapes

- Round-head bolts
 - Square-head bolts
 - Horseshoe-head bolts
 - Headless bolts, shafts with or without locking devices
- The standard design is with forged, heat-treated and machine-finished bolts.
- Different variants of thread ends and cotter pin holes for different application areas
- Special variants:
- With lubricating holes and greasing nipples
 - Closer tolerances
 - Other qualities on request

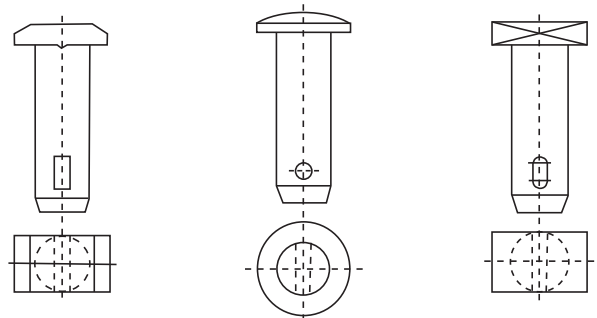

Your advantage:

- Dimensions as specified by customer
- Accessories such as nuts, cotter pins, locking devices etc. available as kits
- No further processing required after installation
- Many years of manufacturing and design experience

FRIESISCHE VERSCHLEISSTECHNIK GmbH & Co. KG

Am Industriepark 16 · 26670 Uplengen · Tel.: +49 4956 4067-0 · Fax: +49 4956 4067-19 · info@fvt-gmbh.de